

Field Day 2023

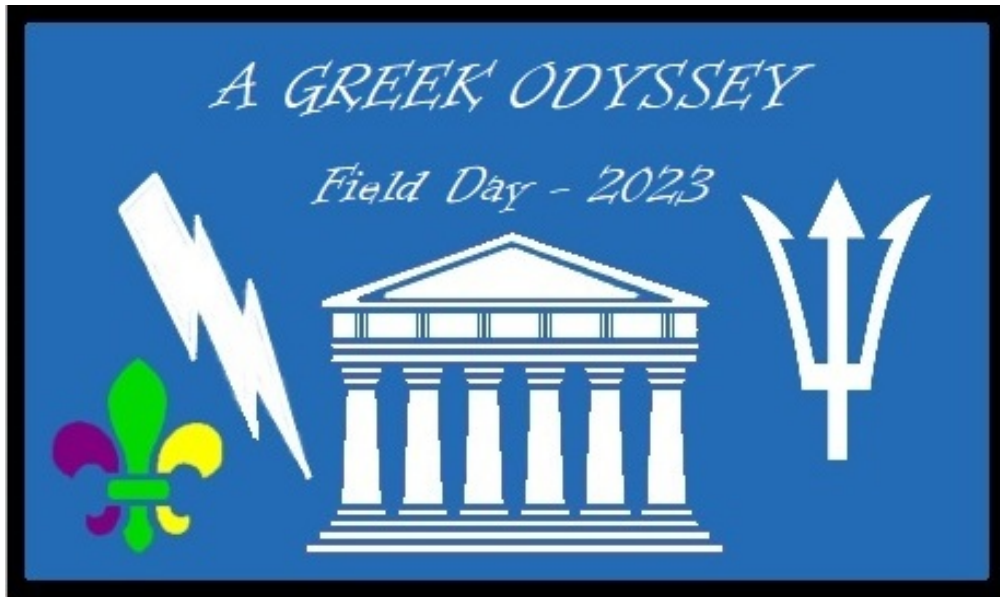

A Greek Odyssey

18 - 20 August 2023

Hartebeestfontein Kämpferrein, Dinokeng

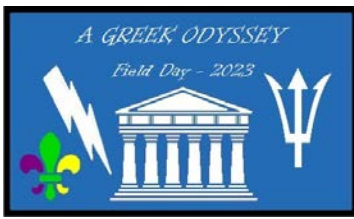

Field Day 2023 Competition & Admin Pack

Contents

Competitions Overview:	3
General Rules	4
Registration Procedure	4
Akela (Hercules) Challenge	5
Camping Competition	6
Cooking Competition	9
First Aid Competition	11
Jolomk'u Competition	12
Orienteering Competition	14
Pioneering Competition:	15
Scoutcraft Competition	17
Stalking Competition	19
Staving Competition	20
Sports Competition:	22
Troop HQ Competition	23
Camp Programme	24
Campsite Layout	27
Directions to Camp	28
Administrative Documents	29

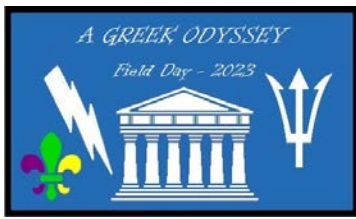

Field Day 2023 Competition & Admin Pack

Competitions Overview:

Troops will be able to compete in various competitions at Field Day to gain points towards the overall competition trophy. Winners will be announced for each competition, with the summation of the points from these competitions determining the overall Field Day winner. Troops do not need to partake in all competitions, however, the more competitions a Troop partakes in, the better the chances of that Troop winning the overall Field Day Trophy.

It is compulsory for a Troop to run an activity as part of the Akela (Hercules) Challenge if that troop wishes to compete for the overall Field Day trophy. Troops not running an activity as part of the Akela (Hercules) Challenge, will not be in contention for the overall Field Day trophy.

The Scout Promise and Law is to be followed at all times throughout the competition. Troops may only enter one team per competition. Refer to each of the competition sections for details and rules pertaining to that competition.

Competitions which will be taking place throughout the weekend are:

- Akela (Hercules) Challenge
- Camping
- Cooking
- First Aid
- Jolomk'u
- Orienteering
- Pioneering
- Scoutcraft
- Staving
- Stalking
- Sports
- Troop HQ

Points will be awarded to Troops who ensure that all their administration is handed in timeously, completed, and correct. This will be checked during registration at Field Day 2023.

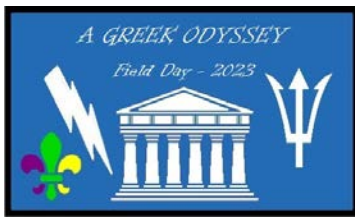

Field Day 2023 Competition & Admin Pack

General Rules

- Scout Promise and Law is the law of Field Day 2023
- Adhere to the Voortrekker Campsite rules and regulations at all times.
- General speed limit in Hartebeestfontein is 15kph.
- Ablutions are specifically designated. These are split between adults and youth. The upper abluion block is for adults only.
- Clean up abluion areas after use.
- Showers, considers others by keeping your shower short and not using up all the hot water.
- All waste is to be bagged and disposed of at the designated areas. No wet or dry pits allowed.
- Do not cross campsite boundaries, use gateways to enter and exit sites.
- Always keep fire safety in mind, the grass is dry this time of the year.
- Lost and found property is to be handed in at the Field Day HQ.
- Scouts are not allowed in the Field Day HQ, kitchen, staff sleeping quarters, or adult ablutions.

Registration Procedure

Once your Troop has arrived at Field Day 2023, the following needs to take place:

- Scouter and Senior PL to report to Field Day HQ.
- Hand in consent forms and consent form summary sheet if it has not been sent prior to Field Day.
- Confirm your Troops competition entries.
- Obtain site allocations for various competitions.

Troops may not begin with any construction or competitions until that Troop's registration has been completed.

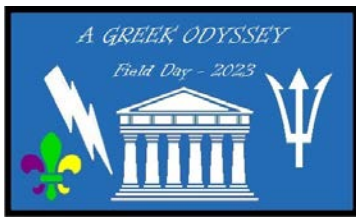

Field Day 2023 Competition & Admin Pack

Akela (Hercules) Challenge

Competition Team:

- Scouts of any age

Competition Site:

- Activities take place within the Troop campsite, unless approved in writing by the Field Day organising team.

Theme: A Greek Odyssey:

- All activities and decorations need to depict this Theme.

Equipment Requirements:

- Troops determine and supply their own equipment required for the competition.

Specific Rules:

- This Akela (Hercules) Challenge is compulsory to qualify for the overall Field Day trophy. Troops that do not partake in this challenge, will not be considered.
- The activity must be run by Scouts for the Cubs as this is not a Scouter run activity. Troops will be penalized should there be adult involvement.

Evaluation:

- Does the activity contribute towards Cub advancements and/or interest badge?
- Was the activity well structured and kept the Cubs busy throughout the challenge?
- Was the activity run well by the Scouts?
- Did the Cubs enjoy themselves throughout the activity?

The Challenge:

- Roughly 150 Cubs are expected to attend. (Groups of 15 to 20 Cubs at a time)
- Each group of Cubs will rotate between all the Troops and have an opportunity to visit each Troop.
- The Challenge runs from 13:00 to 17:00 on Saturday 19 August 2023.
- Try to keep the activity cost to a minimum.

Activities:

- Troops are to submit 3 ideas of an activity which they would like to run to avoid duplicating activities. Ideas will be approved on a first come first served basis.
- Activity ideas are to be submitted together with the Troop entry.
- Cubs should have fun, learn, pass an advancement and/or badge requirement, and go away with a memory of a great time at Field Day.

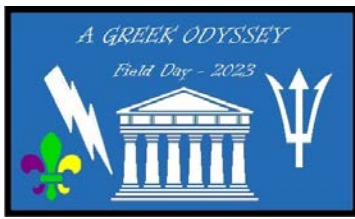

Field Day 2023

Competition & Admin Pack

Camping Competition

Competition Team:

- A patrol of six (06) Scouts will be judged for the competition. However, the entire Troop sets up camp and falls in for inspection.
- The patrol is to be dressed according to the theme during inspections.

Specific Rules:

- Troops are to select their three (03) preferred campsites with their entry. Campsites will be allocated on a first come first served basis upon receipt of entry form and payment.
- Campsites cater for twenty (20) persons with a Maximum of thirty (30), before a second campsite becomes mandatory.
- Extra campsites will only be allocated on receipt of full payment.
- Campsites will be 20m x 25m (or the equivalent ground area in shape).
- Troops may off-load equipment prior to 14:00 on Friday 18 August 2023. Construction of campsites may only begin at 14:00. Disregard of this will result in penalties.
- Scouters and/or adults may assist with off-loading of equipment but must vacate the campsite before construction of the campsite begins. There will be a separate campsite for Scouters and adults. Scouters and/or adults will be allowed back into Troop campsites on Sunday 20 August 2023 after final inspection has taken place. Disregard of this will result in penalties.
- Lights and generators are to be switched off by 22:00 each night. Disregard of this will result in penalties.
- Scouts are to be in bed by 22:30 each night. Disregard of this will result in penalties.
- No wet-pits or hanging bags with drainage systems. All wastewater is to be disposed of in the washing troughs next to the pool.
- All waste (rubbish / food scraps / fire ash) is to be bagged and removed as directed.
- Decorations and costumes pertaining to the theme may be prepared prior to the commencement of the competition.
- Scouts observed crossing over campsite boundaries and not making use of gateways, will incur penalties.
- Penalties will be incurred for bad hygiene, untidiness, non-punctuality, not abiding by the Scout Promise & Law.

Competition Site:

- The entire Troop Campsite (including extra sites) will be the competition site.
- Each campsite must have the following as a minimum requirement:
 - Sleeping area – sufficient tents to accommodate all Scouts, separated for male and female Scouts.
 - Kitchen area – preparation, washing, waste management systems, food storage.
 - Cooking – fireplace or gas stoves, fire-fighting station, fuel storage.
 - Equipment – storage of camp equipment, personal kit.
 - Dining – covered seating area for the number of scouts registered on the entry form plus one judge. Those preparing the camp meals are not required to be seated at the table during meals.
 - Gadgets – gateway, flagpole, guest washstand, notice board.

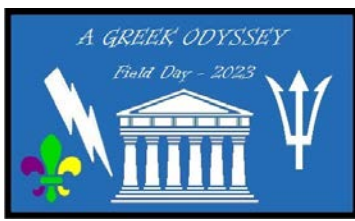

Field Day 2023

Competition & Admin Pack

- Campsite boundary – definitive form of a boundary. Hazard tape is not acceptable.
- Vehicles may not be parked in campsites. There will be a designated parking area.

Marked Meals:

Troops decide on their own menus for the Field Day weekend. Meals will be evaluated on preparation requirements, taste, presentation, nutritional value, keeping with the theme, complexity, punctuality, and whether it was served at the required temperature.

The following meals will be marked at the times indicated:

- Breakfast (Saturday 19 August 2023) - 06:30
- Supper (Saturday 19 August 2023) - 19:30
- Breakfast (Sunday 20 August 2023) - 06:30

Breakfasts – this should be a two (02) course meal consisting of two (02) hot items not including a hot drink. E.g., the Troop may serve a hot milk item as one course and an egg / savoury / meat / or any other item that requires preparation as the second course. A breakfast of a single cereal with cold milk will not score well.

Supper – this should be a three (03) course meal, with at least one of the courses being served hot. E.g., the main course could be served hot while the starter and desert are served cold. Courses are to be served according to the intended temperature of that course. A single course supper will not score well.

Cooking Equipment:

- Troops are to determine and supply their own equipment and meal requirements.
- Troops are to bring their own firewood. No firewood may be taken from the campgrounds.

Rules pertaining to marked meals:

- Judge invitations are to be delivered to Field Day HQ a minimum of fifteen (15) minutes prior to the start time of the meal.
- Judge's mess kit is to be collected when delivering the invitation.
- Judges are to be met by at least two (02) Scouts, dressed according to the theme, at Field Day HQ and escorted to the Troop campsite.
- Cooking may be done using gas or fire.
- Meals are to be served and concluded within thirty (30) minutes.
- The entire Troop must be served the same meal as what is served to the judge.
- Judge's mess kit is to be washed and returned within fifteen (15) minutes after concluding the meal.

Campsite Inspection:

Focus will be placed on Camping Standards: hygiene, safety, site layout, neatness, cleanliness, decorations, design, construction, state of equipment.

Full campsite inspections will take place on the following days and times:

- Saturday 19 August 2023 - 07:45
- Sunday 20 August 2023 - 07:45
- Sunday 20 August 2023 - 10:00

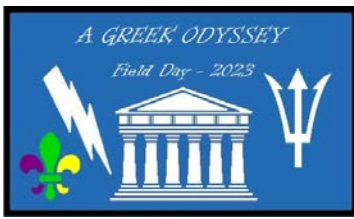

Field Day 2023 Competition & Admin Pack

Rules pertaining to campsite inspection:

- Judges will not wait for Troops to “be ready for inspection”. Inspections will commence at the times indicated above.
- The entire Troop is to fall in for inspection at the indicated times above.
- The selected patrol of six (06) Scouts will be inspected for being dressed according to the theme, with the PL and APL clearly indicated. The entire troop will be inspected for hygiene.
- Unsafe behaviour and behaviour that goes against the Scout Promise and Law will be penalised.
- Campsites are to be returned to a similar condition as it was at the start of the competition for the final inspection.

Campsite Layout

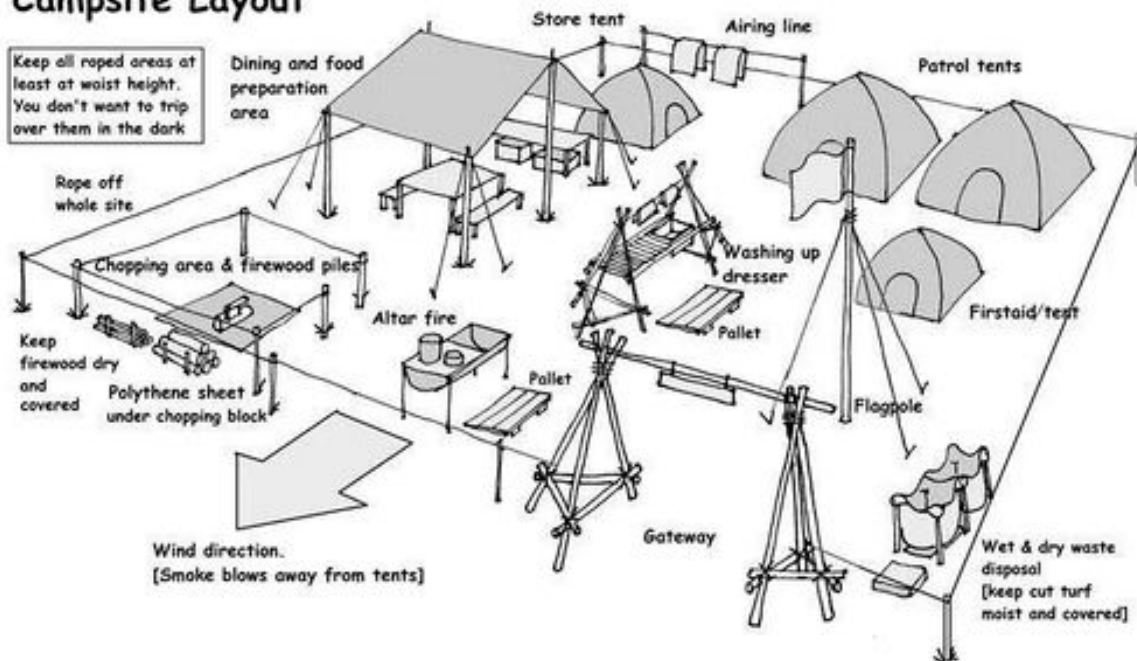

This is a suggested campsite layout. Troops may design their own layout.

Campfire:

This year, Troops will be marked on their participation in the Field Day Campfire as part of the camping competition. Campfire will be held at 20:45 on Saturday 19 August 2023.

Each Troop will be required to perform a skit and lead a song at the campfire.

Troops are to submit their choice of 3 songs and brief description of skit together with their entry so that duplication is avoided. Skits and songs will be assigned on a first come first served basis.

Enthusiasm and execution of skits and songs will be key to scoring well.

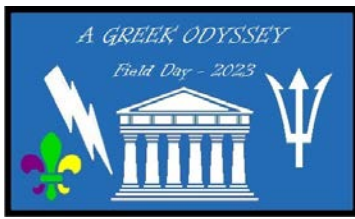

Field Day 2023

Competition & Admin Pack

Cooking Competition

Competition Team:

- A maximum of four (04) Scouts
- Team to be dressed according to the theme throughout the competition with the PL clearly indicated.

Menu:

- Teams will receive a mystery basket of ingredients, which will be handed to the teams on Saturday 19 August 2023 morning @ 06:00.
- Cost of the competition is R200 per team, which will cover the cost of the ingredients.
- Teams are allowed to bring their own condiments, salt, pepper, spices, etc.

Competition Site:

- Each team will cook within the designated area away from the Troop campsite.
- Decorations, notice boards, etc may be prepared prior to the commencement of the competition.
- No holes (wet / ash / rubbish pits) are allowed. All waste is to be bagged and removed from the site.

Equipment Requirements:

- Teams are to supply their own equipment for preparation, cooking, presentation, serving, washing up, utensils, pots, pans, etc.
- Gazebo / shade to work under (very important)
- Firewood / Charcoal / Gas Stoves
- All equipment must be safe and serviceable.

Specific Rules:

- Marks are awarded for preparation, neatness, presentation and decoration, taste, cleanliness of equipment and safety.
- Prepared meals that are presented according to the Field Day theme will score highly.
- Cooking may be done via fire, gas, paraffin or electric (own supply). Safety must be considered.
- An inspection of equipment will be conducted between 08:15 and 08:45 on Saturday 19 August 2023.
- Competition starts at 09:00 on Saturday 19 August 2023.
- The main course must be served at 13:00 and desert by 13:30 on Saturday 19 August 2023.
- Final equipment inspection is done at 14:30.

Evaluation:

- Judges will evaluate the designated place setting and decorations, equipment cleanliness (before & after), preparation, meal presentation and taste.
- Judges will not sit at a table; a panel will judge all entries at the judges' table.
- The menu must be served in portions as follows:
 - 13:00 – serve main course.
 - 13:30 – serve desert.
 - A single full place setting must be done at the judging table.

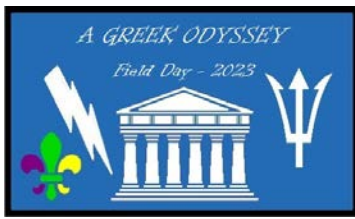

Field Day 2023 Competition & Admin Pack

Competition Format:

- Cost is R200 per team for the ingredients.
- Teams will be given a mystery box of ingredients.
- Teams may start cooking from 09:00 (fires may only be lit from this time).
- Teams are to prepare a main meal and a desert from the ingredients provided to them.

Cooking Equipment:

Please note that all the equipment to be used must be laid out at the cooking site by 08:15 on Saturday 19 August 2023. An equipment list, provided by the team, must be available at the inspection. If equipment has not been inspected, then the team will not be allowed to proceed with the competition.

Final equipment inspection will take place at 14:30 on Saturday 19 August 2023. Teams must have laid out their equipment by 14:30. Teams that are late or who have missing items, against the list provided in the morning, will be penalised.

Dirty and unsafe equipment will be penalised.

Scouter and Adult assistance:

The competition is done by the team of Scouts without any intervention or assistance from Scouters, other adults, or Scouts not part of the team. Anyone not part of the team that is found to be within the designated cooking area during the competition, will incur a penalty per incident.

The chief judge reserves the right to disqualify teams should there be evidence of assistance by those who are not part of the team.

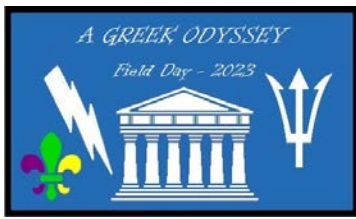

Field Day 2023 Competition & Admin Pack

First Aid Competition

Competition Team:

- A maximum of four (04) Scouts.
- Troop Camp uniform to be worn with an indication of the PL.

Tasks:

The team will deal with various scenarios which cover the principals of First Aid as laid out in the First Aid sections of the Advancement, Scoutcraft, and Interest badges.

Competition Site:

- The First Aid Competition will take place in the Hall at the campgrounds.
- Teams will report for the competition according to a roster which will be made available.
- Teams will be penalized for being late for their scheduled time.

Equipment Requirements:

- Teams must provide their own equipment (use the various first aid requirements in the Theme, Scoutcraft, and Interest badges as a guideline).
- It is suggested that a selection of roller bandages, triangular bandages, and other items to deal with incidents as required in the badges referred to in the previous paragraph be brought along to the competition.
- Bandages and dressings can be made from material. It need not be proper sterilized bandages.
- Complete "Troop First Aid Kit" is not required.

Evaluation:

- Evaluation is based on correct first aid procedure including bandaging and dressing, wound treatment, splinting, evacuation, trauma assessment, patient interaction, etc.
- Team leadership will be assessed.
- Uniformity will be assessed.
- A team of judges will evaluate the scenarios.

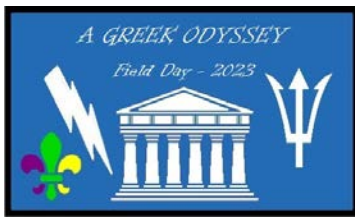

Field Day 2023 Competition & Admin Pack

Jolomk'u Competition

Competition Team:

- Troops may use any number of adults, Scouters, former Scouts, parents. No Scouts.
- Teams to be dressed uniformly and easily identifiable.

Tasks:

- There is one task to be completed, indicated on the next page.

Competition Site:

- Construction will take place within the designated competition area.
- Models and notice boards may be constructed beforehand.

Equipment Requirements:

- Teams are to determine their own equipment requirements, but the dimensions as noted in the task must be adhered to.
- Teams are to supply and transport their own equipment.
- Any type of rope is acceptable, manila, sisal, cotton, polypropylene, or nylon.
- Safety: Pickets – to be adequately covered at tip, any mean except tyres.

Specific Rules:

- Competition starts at 14:00 on Friday 18 August 2023.
- No part of the project may be constructed prior to the start of the competition.
- Pre-Inspection needs to take place before construction begins.
- Competition ends at 13:00 on Saturday 19 August 2023. All teams to cease all construction activity regardless of the state of completion.

Evaluation:

- Evaluation covers construction, accuracy, stability, neatness, functionality, and safety.
- Demonstration in use.
- Correct use of lashings, knots, whipping, proportionality, accuracy, stability, ratios, neatness, functionality, and safety.
- A scale model will be evaluated as well.
- A team of judges will evaluate each of the entries.

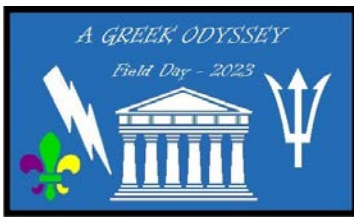

Field Day 2023 Competition & Admin Pack

Task: The Swing Boat

The following minimum requirements must be met:

- A-frame upright poles: minimum 4.8m
- A-frame base poles: minimum 3.6m
- Swing base poles: minimum 4.8m
- Pole base thickness: minimum of 75mm and maximum of 100mm
- Staves will not be accepted.
- Seat: a solid plank and not cardboard.

Minimum requirements not being met will incur penalties.

Safety Alert: Chief Judge reserves the right to declare the project unsafe for use.

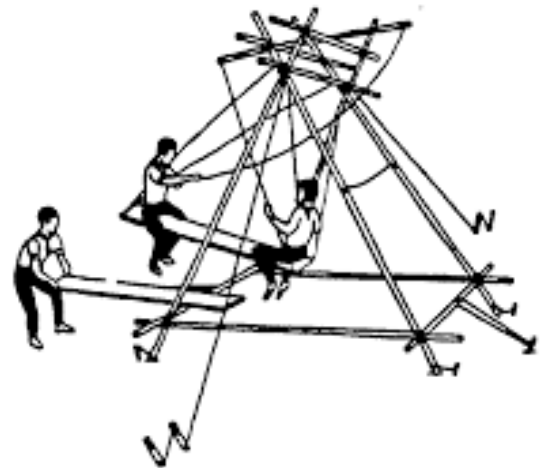
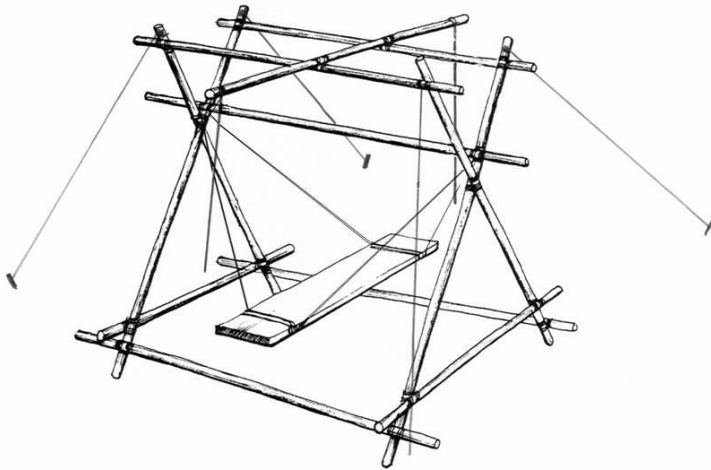

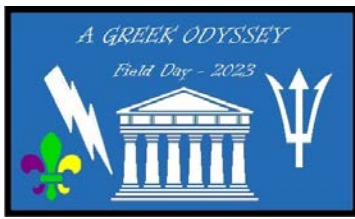

Field Day 2023 Competition & Admin Pack

Orienteering Competition

Competition Teams:

- Junior team of two (02) Scouts (11, 12, and 13 years old)
- Middle team of two (02) Scouts (14 and 15 years old)
- Senior team of two (02) Scouts (16 and 17 years old)
- Troop camp uniform to be worn with an indication of the PL.

Tasks:

- Junior: Plotting points on a map, general map work.
- Middle: Line orienteering, following a compass trail.
- Senior: Point scoring, getting to points from a central location.

Competition Site:

- Teams are to report to the designated competition sites.
- Competition start and end times as per the program.

Equipment Requirements:

- Teams to supply their own equipment.
- Junior: Mapping compass, 360° protractor, 30cm ruler, calculator (base).
- Middle: Mapping compass, water bottles, first aid kit.
- Senior: GPS device, mountain bicycles, high visibility vests, helmets, water bottles, first aid kit.

Specific Rules:

- Evaluation requires correct codes / sequence / completion of tasks.
- Members of the middle and senior teams may not split up.
- Teams may not assist each other, e.g., the senior team assisting the junior team.
- Teams may not remove markers, codes, or pointers.

Evaluation:

- A team of judges will evaluate each of the entries.
- The three age groups will earn their own trophies, but the results will be collated for the Overall Trophy.
- Answer sheets will not be accepted after the competition end time.

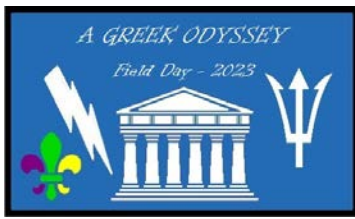

Field Day 2023 Competition & Admin Pack

Pioneering Competition:

Competition Team:

- A maximum of six (06) Scouts.
- Troop camp uniform must be worn with an indication of the PL.

Task:

- There is one (01) task to be completed, indicated on the next page.

Competition Site:

- Construction will take place within the designated competition area.
- Models and notice boards may be constructed beforehand.

Equipment Requirements:

- Teams are to determine their own equipment requirements, but the dimensions as noted in the task must be adhered to.
- Teams are to supply and transport their own equipment.
- Any type of rope is acceptable, manila, sisal, cotton, polypropylene, or nylon.

Specific Rules:

- Competition starts at 14:00 on Friday 18 August 2023.
- No part of the project may be constructed prior to the start of the competition.
- Pre-Inspection needs to take place before construction begins.
- The task needs to be completed by 14:00 on Saturday 19 August 2023. Time extensions will be granted at five (05) penalty points per ten (10) minutes. Only ten (10) minute extensions are available whether fully sued or not.
- Evaluation is based on Pioneering Principles. Correct use of lashings, knots, whipping, holdfasts, mousing, block and tackles, proportionality, accuracy, stability, ratios, raising and lowering, neatness, functionality, safety. Teamwork, model, and overall impression.
- Any member of the Troop may assist with advice and support, but may not tie lashings, knots, nor build any part of the project. All incidents of this observed by a Field Day judge, will result in penalties per occasion.

Evaluation:

- A team of judges will evaluate the project.

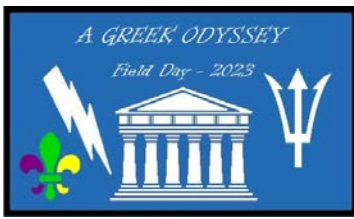

Field Day 2023 Competition & Admin Pack

Task: The Single Lock Bridge

The following minimum requirements must be met:

- Trestle leg poles: minimum 3m
- Trestle ledger poles: minimum 2.4m
- Trestle cross brace poles: minimum 3m
- Trestle transom pole: minimum 2.4m
- Walkway lateral poles: minimum 6m
- Walkway cross spars: minimum 1m
- Distance for bridge to span end to end: minimum 10m.
- Pole base thickness: minimum of 75mm and maximum of 100mm
- Staves will not be accepted.

Minimum requirements not met will incur penalties.

Safety Alert: Chief Judge reserves the right to declare the project unsafe for use.

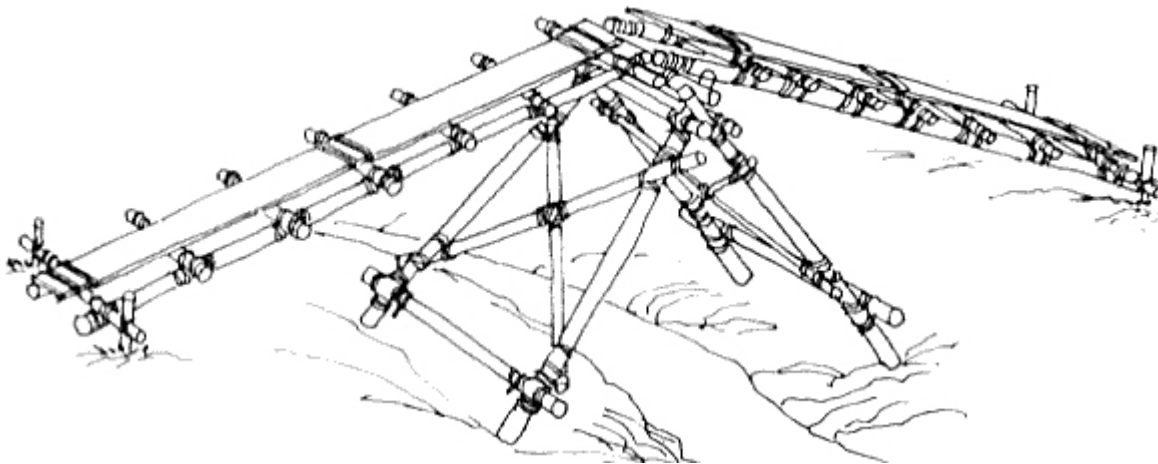

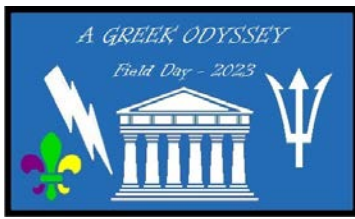

Field Day 2023 Competition & Admin Pack

Scoutcraft Competition

Competition Team

- A maximum of four (04) Scouts.
- Scouts may not interchange / swop during competition.
- Troop Camp uniform must be worn with an indication of the Team leader.

Tasks

- Competition packs will be handed out at 09:00 on Saturday 19 August 2023.

Site

- Teams must complete the tasks in the designated area (not in campsites).
- Troops may bring refreshments to Scouts.

Equipment Requirements

- Teams are to bring the items on the attached list (not definitive – you may bring more should you feel the urge).
- Not all the items listed may be used during the competition.

Specific Rules

- Tasks require planning, ingenuity, mental dexterity, creative skills, teamwork, success, correctness, accuracy, adaptability, lateral thinking, problem solving and social skills.
- Competition closes at 12:00 on Saturday 19 August 2023. No extension of time will be given, irrespective of the number of tasks completed.

Evaluation

- A team of judges will evaluate various tasks in this category.
- Places will be decided in the following order:
- Shortest time to correctly complete all activities.
- Shortest time to complete the most activities correctly.
- If a tie occurs (same time to complete the same number of activities correctly) – then the points for that position plus the next one down will be shared.

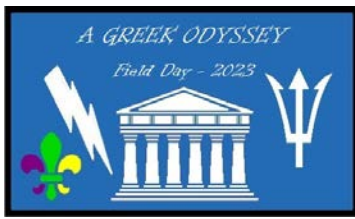

Field Day 2023 Competition & Admin Pack

Equipment

The following list is suggested (there **are** some red herrings):

- 01 x flat nosed and thin nosed pliers
- 01 x roll of fishing line (light breaking strain)
- 01 x 100g ball of string (called "1mm cotton twine" in shops)
- 02 x craft knives (like a Stanley knife)
- 02 x tubes glue (general adhesive)
- 01 x 80g Pritt Stick
- 01 x bottle wood glue
- 02 x scissors
- 02 x 30 cm ruler
- 01 x 20cm square of pine plywood (or tomato box side)
- 01 x 9cm nail
- 01 x 360° protractor
- 01 x kitchen towel tube
- 01 x packet Press-stick
- 01 x cell phone
- 01 x roll Sellotape / magic tape
- 01 x roll wire (very thin / light)
- 01 x roll tin foil
- 01 x analogue watch
- 08 x 410 g tin cans (baked bean type)
- 02 x 720g tin cans (large jam type)
- Anything that a well-prepared Scout would carry.
- Stationery (pencils, pens, erasers, rulers, coloured pencils)
- 02 x clipboards
- Blank A4 paper (any colour)
- 01 x exam pad (i.e., ruled writing paper)
- 01 x packet cotton wool
- Matches / lighter.
- 1.2 m light stave or broom stick
- Large straight tent peg 300mm long
- My Scout Journey

Note: There is a mixture of activities from Scoutcraft to mental alertness.

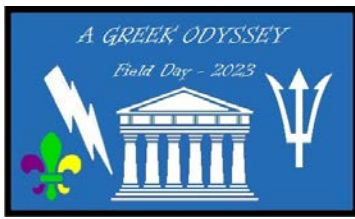

Field Day 2023 Competition & Admin Pack

Stalking Competition

Competition Team:

- A maximum of four (04) Scouts.

Competition Site:

- Competition will take place on Hartebeestfontein.

Competition Format:

- Duration will be ninety (90) minutes.
- It will be a night stalking game on Friday 18 August 2023.
- Teams are to place their flags as close as possible to the judge's flag without being detected.
- Teams must recover various objects while making their way towards the judge's flag.

Equipment Requirements:

- Any type of camouflage material is allowed.
- 200mm square flag for each team member of your own design.

Rules:

- A team of assistant judges will move freely in the game area.
- A whistle will be sounded at the start of the game.
- A long whistle will be sounded at the end of the game.
- Stalkers may not move once the end whistle has sounded. Disqualification will occur should a stalker move after the end whistle.

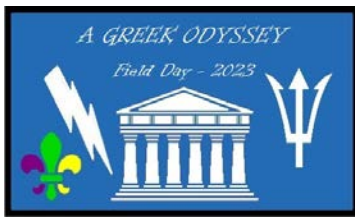

Field Day 2023 Competition & Admin Pack

Staving Competition

Competition Team:

- A maximum of four (04) Scouts
- Troop camp uniform must be worn with an indication of the PL.

Tasks:

- There are two (02) tasks to be completed, indicated on the next page.

Competition Site:

- Construction will take place within the designated competition area.
- Models and notice boards may be constructed beforehand.

Equipment Requirements:

- Teams are to determine their own equipment requirements, but the dimensions as noted in the task must be adhered to.
- Teams are to supply and transport their own equipment.
- Any type of rope is acceptable, manila, sisal, cotton, polypropylene, or nylon.

Specific Rules:

- Competition starts at 14:00 on Friday 18 August 2023.
- No part of the project may be constructed prior to the start of the competition.
- Pre-Inspection needs to take place before construction begins.
- The tasks need to be completed by 14:00 on Saturday 19 August 2023. Time extensions will be granted at five (05) penalty points per ten (10) minutes. Only ten (10) minute extensions are available whether fully sued or not.
- Evaluation is based on Pioneering Principles. Correct use of lashings, knots, whipping, holdfasts, mousing, block and tackles, proportionality, accuracy, stability, ratios, raising and lowering, neatness, functionality, safety. Teamwork, model, and overall impression.
- Any member of the Troop may assist with advice and support, but may not tie lashings, knots, nor build any part of the project. All incidents of this observed by a Field Day judge, will result in penalties per occasion.

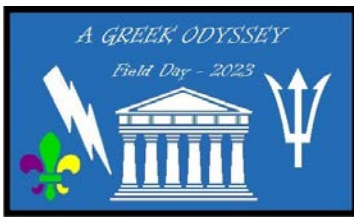

Field Day 2023 Competition & Admin Pack

Task 1: Greek Chariot

Notes:

- This chariot is to be used to escort the camping meal judge from Field Day HQ to the Troop campsite.
- An adult is to be carried in the chariot, therefore ensure that there is enough space for the adult and is strong enough to support their weight.

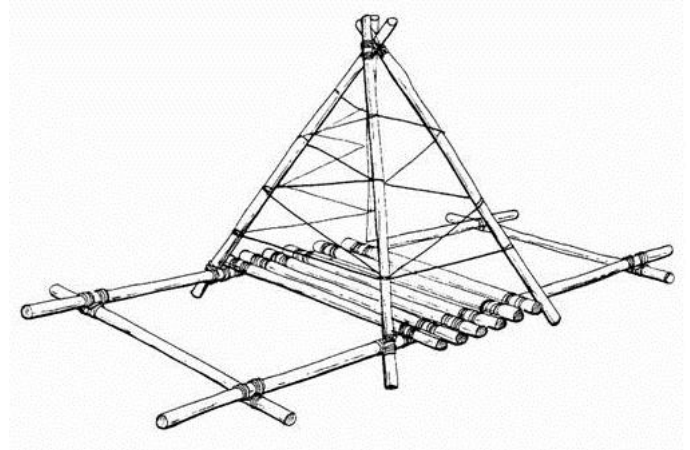

Task 2: Camp Seesaw

Note:

- "A frame" side staves must be 2.4m
- chassis staves ("A frame" joiners) must be 0.9m
- plank must be 2.4m
- Rocker pole (NOT stave) to be 1.8m
- any style of rope may be used.

Evaluation

- Two Scouts to use seesaw.
- Stability of project.
- Tightness of lashings.

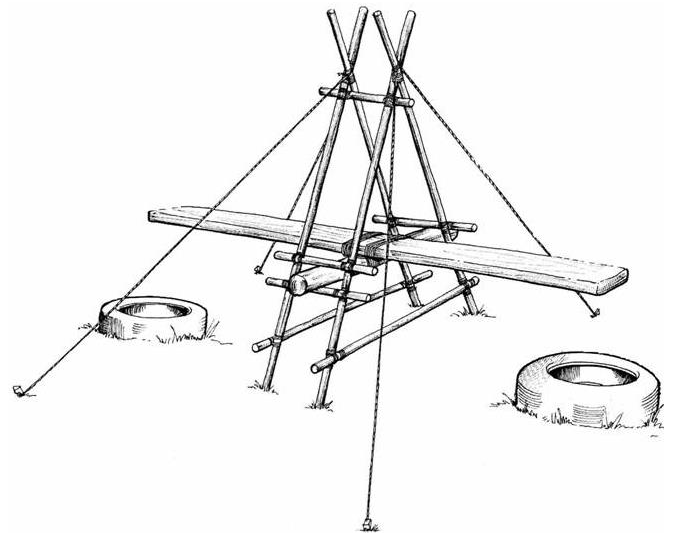

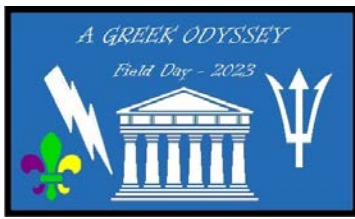

Field Day 2023

Competition & Admin Pack

Sports Competition:

Competition Teams:

- Marksmanship – Two (02) Scouts per age group.
- Tug-o-War – Six (06) Scouts per age group.
- Volleyball – Six (06) Scouts per age group.

Age Groups:

- Junior: 11 – 14 years
- Senior: 15 – 17 years

Competition Sites:

- Marksmanship will take place at the shooting range.
- Tug-o-War and Volleyball will take place on the parade ground.

Specific Rules:

- Each sport has its own trophy.
- The combination of points across all three (03) sports will determine the overall sports winner.
- Marksmanship:
 - Only weapons supplied Field Day may be used.
 - The range officer is always in charge and has the final say. Disregard of the range officer will result in disqualification.
 - Juniors may shoot in the senior competition; seniors may not shoot in the junior competition.
- Tug-o-War:
 - Anchors may not tie the rope around their waists.
 - Takkies or hiking boots may be worn, sporting cleats with spikes are not allowed.
 - Gloves are not allowed.
 - Best of three (03) pulls wins the round.
 - Umpire's decision is final.
- Volleyball:
 - Takkies or hiking boots may be worn, sporting cleats with spikes are not allowed.
 - Gloves may not be worn.
 - One (01) match is played to determine the winner of the round.
 - Umpire's decision is final.

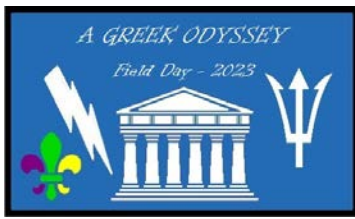

Field Day 2023 Competition & Admin Pack

Troop HQ Competition

Competition Team:

- All Scouts.
- No adults to assist with setting up of the Troop HQ.

Competition Site:

- Troop HQ is within the allocated Troop Campsite.

Equipment Requirements:

- Troops to determine and supply their own equipment.
- All items required are to be supplied by the Troop.
- Each Troop HQ must have the following as a minimum:
 - Details on the Akela (Hercules) Challenge being offered by the Troop.
 - Welcome area for guests visiting the Troop (refreshments, rest area).
 - Decorations according to the theme of Field Day.
 - Information pertaining to the Group itself.
 - Advancement progress charts.
 - 2023 programme plan of the Troop.

Specific Rules:

- Evaluation considers HQ layout, cleanliness, decoration, design, construction, information, refreshments.
- Troop HQ is not a compulsory competition for Troops who wish to qualify for the overall trophy.

Evaluation:

- Evaluation will be done at 10:30 and 13:30 on Saturday 19 August 2023 by a team of judges.

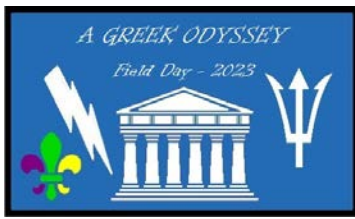

Field Day 2023 Competition & Admin Pack

Camp Programme

Friday 18 August 2023

Time	Activity	Location
14:00	Troops Arrive at Hartebeestfontein Registration Camping, Troop HQ: Competitions start Pioneering, Staving, Jolomk'u: Competitions start	Dinokeng Camp HQ Campsites Competition sites
18:00	Scouter & Senior PL briefing session	Camp HQ
19:00	Supper	Campsites
20:00	Stalking: Competition starts	Competition site
21:30	Stalking: Competition ends	
22:00	Lights out & generators off	Campsites
22:30	All Scouts in bed	Campsites

Notes:

- Troops not represented at briefing session will incur penalty points against overall competition standing.

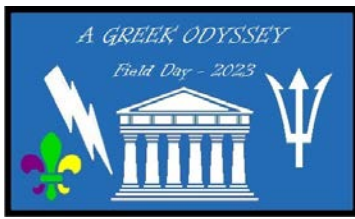

Field Day 2023 Competition & Admin Pack

Saturday 19 August 2023

Time	Activity	Location
05:30	Rise and shine	Campsites
06:00	Cooking: Collection of mystery box	Competition site
06:30	Camping: Breakfast evaluation	Campsites
07:45	Camping: Campsite inspection	Campsites
08:15	Cooking: Equipment inspection	Competition site
08:45	Opening ceremony	Main parade ground
09:00	Cooking, First Aid, Orienteering, Scoutcraft, Marksmanship: Competitions start	Competition sites
10:30	Troop HQ: First inspection	Campsites
12:00	First Aid, Orienteering, Scoutcraft: Competitions end	
12:30	Lunch	Campsites
13:00	Jolomk'u: Competition ends Cooking: Main course evaluation Akela (Hercules) Challenge: Competition starts	Competition site Campsites
13:30	Cooking: Desert course evaluation Troop HQ: Second inspection	Competition site Campsites
14:00	Pioneering, Staving: Competition ends	
14:30	Cooking: Final inspection	Competition site
15:00	Tug-o-War, Volleyball: Competition starts	Main parade ground
17:00	Akela (Hercules) Challenge: Competition ends	
18:00	Marksmanship, Tug-o-War, Volleyball: Competitions end	
19:30	Camping: Supper evaluation	Campsites
20:45	Camping: Field Day 2023 Campfire	The Boma
22:00	Lights out & generators off	Campsites
22:30	All Scouts in bed	Campsites

Notes:

- Troops to be fallen in for opening parade by 08:40
- Winners of Field Day 2022 (10th Arcadia) are to supply Troop flag for parade flagpole and break the flag for opening parade.
- Teams to constantly check notice boards for competition time allocations as well as judge allocations for camping meal evaluations.

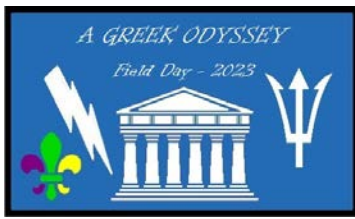

Field Day 2023 Competition & Admin Pack

Sunday 20 August 2023

Time	Activity	Location
05:30	Rise and shine	Campsites
06:30	Camping: Breakfast evaluation	Campsites
07:45	Camping: Campsite inspection	Campsites
10:00	Camping: Final inspection	Campsites
11:00	Scout's Own	Main parade ground
11:30	Closing ceremony	Main parade ground
12:00	Departure from Field Day 2023	Hartebeestfontein

Notes:

- Winners of Field Day 2023 are to lower the flag at closing ceremony.
- Remove all barrier tape from campsites.
- All waste to be bagged and placed in designated areas for removal.
- Check lost property before departure.

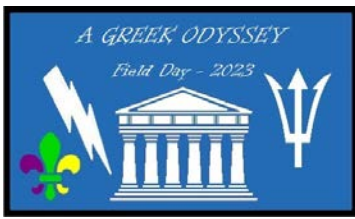

Field Day 2023 Competition & Admin Pack

Campsite Layout

Notes:

- Subcamp A has no electricity and will require a generator.
- Subcamp B has electrical points, Troops need to supply their own extension cables.
- The ground in Subcamp B is dry and dusty, whereas Subcamp A is grassy.
- The ablutions closest to Subcamp B are for adults only, Scouts may not make use of these ablutions.

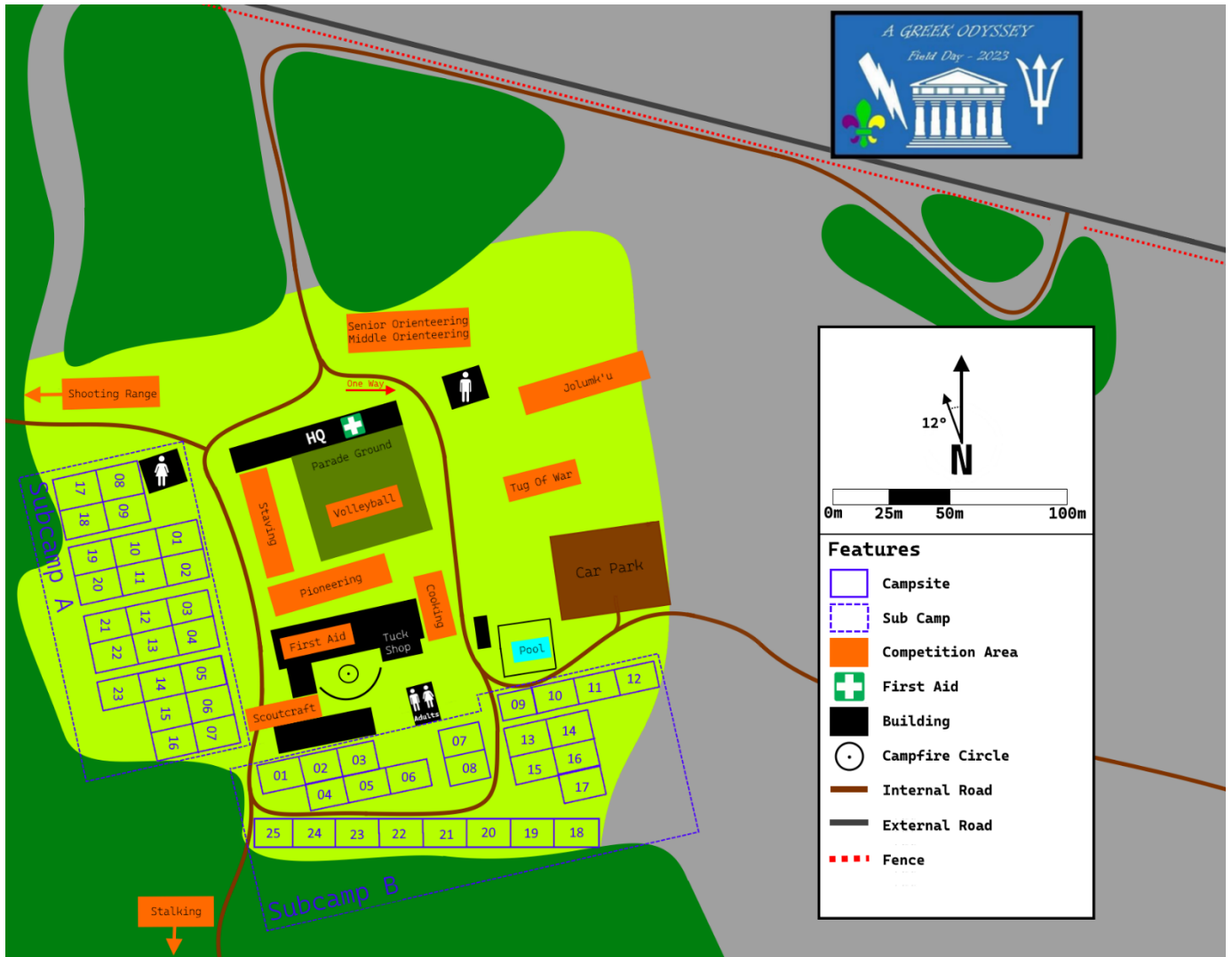

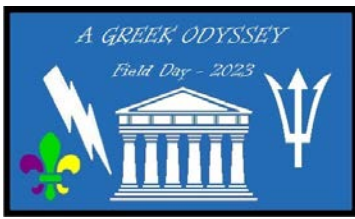

Field Day 2023 Competition & Admin Pack

Directions to Camp

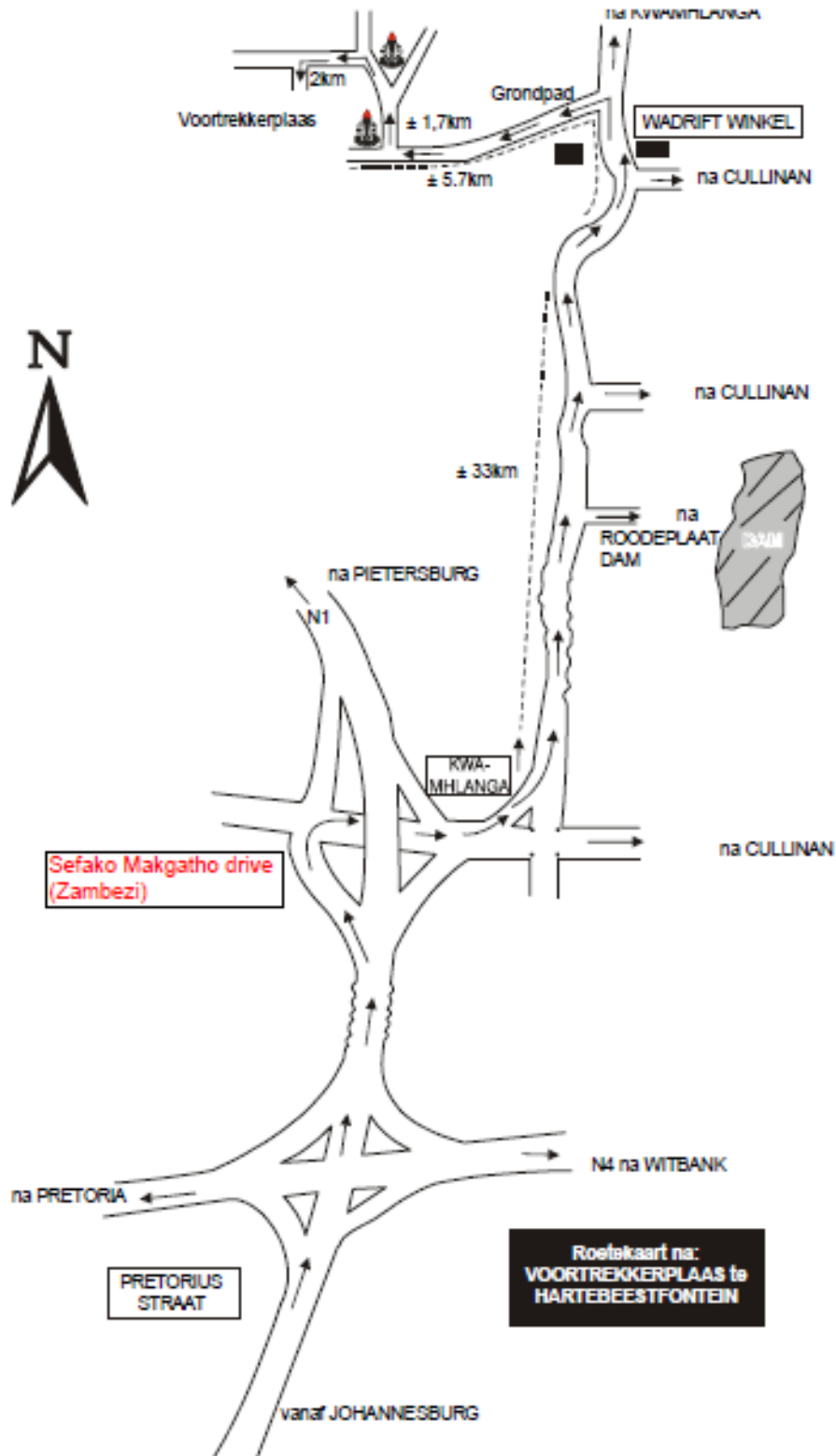

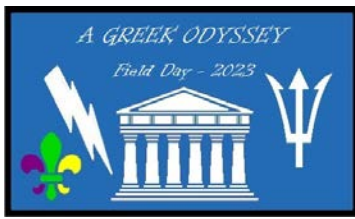

Field Day 2023 Competition & Admin Pack

Administrative Documents

This year, we are going to be going paperless and do everything online.

The following documents can be accessed using the provided web links:

- Troop Entry Form (Troop Scouter to complete) – <https://forms.office.com/r/W3Eat1xwr6>
- Pack Entry Form (Pack Scouter to complete) – <https://forms.office.com/r/whFyxAFC5a>
- The following consent forms can be downloaded using the provided link:
 - Adult Consent Form
 - Cub Consent Form
 - Cub Consent Form Summary Sheet
 - Scout Consent Form
 - Scout Consent Form Summary Sheet

<https://shorturl.at/cAOT6>

A reminder that the closing date for entries is Sunday 30 July 2023. All trophies need to be returned to the Tshwane Scout Shop by Saturday 22 July 2023. Troops who have not returned trophies in their possession will be disqualified.

Consent forms together with the summary sheet are to be submitted as a single pack per Troop/Pack, either via email or shared via cloud storage. We can make a shared folder available for you to upload your documents to upon request. Please use email the Field Day email address for submission of documents or queries: gt.fieldday@scouts.org.za

Costs:

- Scouts & Troop Scouters – R280 per person (includes badge)
- Cooking competition – R200 per team
- Cubs & Pack Scouters – R140 per person (includes badge)
- Day visitors – R110 per person
- Family & friends wanting to camp – R125 per person per night.

Banking Details:

Bank	-	Standard Bank
Account	-	SASA – Tshwane Region
Branch	-	Sunnyside
Branch Code	-	010645
Account No.	-	011505451
Reference	-	Troop Name FD (e.g.: MenloFD)

Do join our WhatsApp Community to stay up to date with all communications prior and during Field Day 2023: <https://chat.whatsapp.com/K1tD6uhDUvRBcJJzohDjP>

We are looking forward to a fun filled weekend with you all.

Yours in Scouting

Neil Marshall (Camp Chief) – 072 235 9442

Hamish Arendse (Chief Judge) – 082 645 5537